

# TOWN OF DANVILLE

## Town Council Agenda

**August 21, 2024**

**\*\*\*6:00 PM\*\*\***

**Please note change in start time**

- I. Establish Quorum, Call Meeting to Order**
- II. Pledge of Allegiance**
- III. Approval of Minutes**
- IV. Public Comment** – 3 minutes per person
- V. Public Meeting**
  - A. Badge Pinning Ceremony – Fire Department**
  - B. Budget Introduction – Clerk/Treasurer & Baker-Tilly**
  - C. Change Order #4: Water Plant – Banning Engineering/Water Department**
  - D. Ordinance 18-2024: Amendment to Salary Ordinance – Clerk/Treasurer**
  - E. Ordinance 19-2024: Additional Appropriation – Clerk/Treasurer**
  - F. Conflict of Interest Form: Corey Caylor – Town Manager**
  
- VI. Staff and Council Comments**
- VII. Claim Docket**
- VIII. Payroll Docket**
- IX. Adjournment**

**NOTICE:** The public meetings of the Danville Town Council conducted within these chambers shall be video recorded. Said recording will be part of the public records of the Town of Danville and shall be published upon the Town of Danville's website for public access. All individuals attending public meetings hereby give to the Town of Danville, their permission for said publication, which may contain their image or statements.

## TOPIC SUMMARY

### **Approval of Minutes:**

**8/7/24: Council Meeting.** *Will require a Vote.*

- A. Badge Pinning** – Fire Department will present employees that have successfully completed their probationary period and are eligible for full-time status. Family and friends will be present for the Badge Pinning Ceremony. **Please allow time for photographs.** *Requires no further action.*
- B. Budget Introduction** – Susan Cowen of Baker Tilly and the Clerk/Treasurer will present the 2025 Budget as an introduction only. It is requested that questions be submitted for the 9/4/24 Work Study Session. *Requires no further action.*
- C. Change Order #4: Water Treatment Plant** – Kent Elliott of Banning Engineering along with the Water Superintendent will present a Change Work Order for the Water Treatment Facility. *Will require a Vote.*
- D. Ordinance 18-2024: Amendment to Salary Ordinance** – Clerk/Treasurer, along with Fire Chief, will present an amendment to the Salary Ordinance to create a new title for civilian EMT and stipend for Paramedics. This will not create any new hires, only titles. This is up for introduction only tonight. *Requires no further action.*
- E. Ordinance 19-2024: Additional Appropriation** – Clerk/Treasurer will present an ordinance requesting an additional appropriation in the EDIT fund for “Other Services and Charges”. This has been properly advertised pursuant to Indiana Statute. This is up for a public hearing. **Public Hearing will need to be gavelled open – Public Comment Taken – Public Hearing gavelled closed.** As a result of these actions, this is up for adoption tonight. *Will require a Vote.*
- F. Conflict of Interest Form: Corey Caylor** – Employee has entered into a new business of hosting ATM’s at certain locations, including the local towing service. Employee is amending his Conflict of Interest forms to include this activity. *Will require a Vote.*

### **Staff and Council Comments**

**Claim Docket**

**Payroll Docket**

**Motion to Adjourn**

**\*\*\*Council Members are requested to stay and sign documents after the close of the meeting\*\*\***

Date of Issuance: 08/07/2024  
 Owner: TOWN OF DANVILLE, IN  
 Contractor: PATTERSON HORTH, INC.  
 Engineer: BANNING ENGINEERING, INC.  
 Project: WATERWORKS IMPROVEMENTS

Effective Date: 08/07/2024  
 Owner's Contract No.:  
 Contractor's Project No.:  
 Engineer's Project No.: 20126  
 Contract Name: DIVISION 2 –  
 WATER TREATMENT PLANT

The Contract is modified as follows upon execution of this Change Order:

Description: COR #07 – Columbia Street ADA Crossing .....	\$28,020.00	Reason: OWNER REQUESTED
COR #09REV1 – Unsuitable Soils for Road.....	\$36,918.00	Reason: UNFORSEEN CONDITIONS
COR #10 – Duct Insulation .....	\$1,786.00	Reason: OWNER REQUESTED
COR #13REV1 – Division 4 Final Quantities .....	\$61,119.20	Reason: FIELD ADJUSTMENTS
COR #14 – Well 5 Electrical Service .....	\$11,989.00	Reason: FIELD ADJUSTMENTS
THIS IS A \$139,832.20 ADDITION.		

Attachments: PATTERSON HORTH CHANGE ORDER REQUESTS #07, #09REV1, #10, #13REV1, #14.

CHANGE IN CONTRACT PRICE	CHANGE IN CONTRACT TIMES [note changes in Milestones if applicable]
Original Contract Price:  \$ <u>9,900,000.00</u>	Original Contract Times: Substantial Completion: <u>March 14, 2024</u> Ready for Final Payment: <u>April 13, 2024</u> days or dates
Increase from previously approved Change Orders No. <u>0</u> to No. <u>3</u> :  \$ <u>2,594,348.00</u>	Increase from previously approved Change Orders No. <u>0</u> to No. <u>3</u> : Substantial Completion: <u>90 days</u> Ready for Final Payment: <u>90 days</u> days
Contract Price prior to this Change Order:  \$ <u>12,494,348.00</u>	Contract Times prior to this Change Order: Substantial Completion: <u>June 12, 2024</u> Ready for Final Payment: <u>July 12, 2024</u> days or dates
Increase of this Change Order:  \$ <u>139,832.20</u>	Increase of this Change Order: Substantial Completion: <u>60 days</u> Ready for Final Payment: <u>60 days</u> days or dates
Contract Price incorporating this Change Order:  \$ <u>12,634,180.20</u>	Contract Times with all approved Change Orders: Substantial Completion: <u>August 11, 2024</u> Ready for Final Payment: <u>September 10, 2024</u> days or dates

RECOMMENDED:	ACCEPTED:	ACCEPTED:
By: <u>Kent S. Elliott</u>	By: <u>Chris Gerald</u>	By: <u>Jim Alstatt</u>
Title: <u>Project Manager</u>	Title: <u>Town Council President</u>	Title: <u>Vice President</u>
Date: <u>8/02/2024</u>	Date: <u>8/21/2024</u>	Date: <u>8/02/2024</u>



**PATTERSON HORTH**  
GENERAL CONTRACTORS

Change Order Request #07

TITLE: Road Crossing Changes ADA

DATE: 9/19/2023

PROJECT: Danville WTP

PROJECT # 22232

TO: Banning Engineering

DESCRIPTION OF PROPOSAL

Per sheet 100 issued by Banning Engineering on 8/24/23, grading and asphalt changes associated with the intersection of Sycamore Lane and E. Columbia Street for ADA compliance. **Concrete Work and Signage removal/reinstall by Town of Danville.**

ITEM#	DESCRIPTION	QUANTITY	UNIT	UNIT PRICE	TOTAL
1.	Layout/Engineering	1	LS	\$ 2,500.00	\$ 2,500
2.	John Hall - Grading changes west of Columbia Street	1	LS	\$ 12,460.00	\$ 12,460
3.	Fox - Grading changes east of Columbia Street	1	LS	\$ 5,500.09	\$ 5,500
4.	Globe - Asphalt changes	1	LS	\$ 5,896.00	\$ 5,896
				Subcontractor Total	\$ 26,356
				Subtotal	\$ 26,356
				Self Perform PH FEE (15%)	\$ -
				Subcontractor PH FEE (5%)	\$ 1,318
				Bonds & Insurance (1.25%)	\$ 346
				<b>Total Add</b>	<b>\$ 28,020</b>

**Patterson Horth, Inc.**  
5745 Progress Drive  
Indianapolis, Indiana 46241  
p: 317-243-6104  
f: 317-243-6398



**GLOBE ASPHALT PAVING CO., INC.**

6445 E. 30th St.  
P.O. Box 19168  
Indianapolis, IN 46219

(317) 568-4344  
Fax 568-4277

*PROPOSAL*

<b>To:</b> Patterson - Horth, Inc.	<b>Contact:</b> Jim Alstatt
<b>Address:</b> 5745 Progress Rd. Indianapolis, IN 46241	<b>Phone:</b> 243-6104 <b>Fax:</b> 243-6398
<b>Project Name:</b> Waterworks Improvements - Town Of Danville	<b>Bid Number:</b>
<b>Project Location:</b> E Colummbia St, Danville, IN	<b>Bid Date:</b> 9/19/2023

Item #	Item Description	Estimated Quantity	Unit
1	New 6' Path - Install 4" Stone + 2.5" Binder + 1.5" Surface	22.00	SY

**Total Bid Price: \$5,896.00**

**Notes:**

- Indiana sales tax on materials is included in our proposal.
- This proposal is valid for 30 days.

**Payment Terms:**

Net payment 30 days upon completion and receipt of invoice.

*PUT*

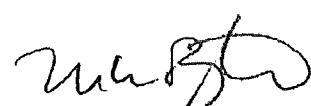
<p><b>ACCEPTED:</b> The above prices, specifications and conditions are satisfactory and are hereby accepted.</p> <p><b>Buyer:</b> _____</p> <p><b>Signature:</b> _____</p> <p><b>Date of Acceptance:</b> _____</p>	<p><b>CONFIRMED:</b> <b>Globe Asphalt Paving Co., Inc.</b></p> <p><b>Authorized Signature:</b> </p> <p><b>Estimator:</b> Mark Pennington 317-568-4344 mpennington@globeasphalt.com</p>
---	---



## Fox Contractors Corp.

5430 W. Ferguson Fort Wayne, Indiana 46809-9612  
Ft. Wayne (260) 747-7461 Fax (260) 747-7717  
Whitestown (317) 769-6291 Fax (317) 769-6294  
www.foxcontractors.com

18-Sep-23

Jim Alstatt  
Project Manager  
Indianapolis

Project: Danville WWTP - Div 2  
22-123  
Fox Job No: 22-123

RE: Added grading at path area

Please find herewith and attached the additional excavation associated with the added path work at the E. Columbia and Sycamore intersection. Pricing is only included for the East side of E. Columbia Street.

<i>item</i>	<i>spec</i>	<i>description</i>	<i>quantity</i>	<i>unit</i>	<i>unit price</i>	<i>total price</i>
		Additional Demo and Grading work	1.00	ls	\$ 5,500.09	\$ 5,500.09
						Total: \$ 5,500.09

Please issue a change order at your convenience so we can incorporate these changes into our subcontract.

Respectfully yours;

Parker Smith  
Project Manager

Cc: A. Smith, Job File 22-052

COMPANY NAME <b>Fox Contractors Corp.</b>			DATE: 9/18/2023	PAGE: 1
			DAY:	OF:

PO/RFI/PCI Number	RELEASE NO.	A.R. NO.	JOB NO. 22-052 Passage Apartments - 22-052
-------------------	-------------	----------	---

EXTRA WORK DESCRIPTION <b>Additional Demo and Grading work</b>	Quantity: 1 ls
---	----------------

LABOR (base wage+fringes+insurance/taxes) n.i.c. W/C or GL							
CRAFT	REG HRS	OT HRS	DT HRS	RATE REG HRS	RATE OT HRS	RATE DT HRS	TOTAL
Superintendent				74.77	99.38	123.99	\$ -
Forman	8			74.77	99.38	123.99	\$ 598.18
Operator	16			72.47	97.08	121.69	\$ 1,159.57
Mechanic				70.13	93.56	117.00	\$ -
Teamster	4			60.54	81.05	101.58	\$ 242.14
Laborer/Teamster Combo				62.38	82.89	103.42	\$ -
Laborer - Finisher				54.38	70.99	87.60	\$ -
Laborer - Pipe				54.73	71.33	87.94	\$ -
Laborer - General	8			53.23	69.84	86.45	\$ 425.87
<b>TOTAL DIRECT LABOR COST:</b>							<b>\$ 2,425.76</b>

SUBCONTRACTOR					
NAME	DESCRIPTION	Qty	Unit	Unit Price	TOTAL
					\$ -
					\$ -
					\$ -
					\$ -
<b>TOTAL SUBCONTRACTOR:</b>					<b>\$ -</b>

MATERIALS				
QUANTITY	DESCRIPTION	UNIT	UNIT PRICE	TOTAL
2	Dump Fee - Asphalt	LD	\$ 200.00	\$ 400.00
				\$ -
				\$ -
				\$ -
				\$ -
				\$ -
				\$ -
				\$ -
				\$ -
				\$ -
				\$ -
				\$ -
				\$ -
				\$ -
				\$ -
				\$ -
				\$ -
				\$ -
				\$ -
				\$ -
<b>SUB-TOTAL DIRECT MATERIALS:</b>				<b>\$ 400.00</b>
			Tax	\$ 28.00
<b>TOTAL DIRECT MATERIALS WITH TAX:</b>				<b>\$ 428.00</b>

EQUIPMENT							
HOURS	TYPE OF EQUIPMENT	RATE	TOTAL	HOURS	TYPE OF EQUIPMENT	RATE	TOTAL
8	Forman Truck	\$ 26.00	\$ 208.00		Backhoe	\$ 66.00	\$ -
	Lowboy & Trailer	\$ 133.00	\$ -		Grader	\$ 176.00	\$ -
4	Tri-Axle	\$ 63.00	\$ 252.00		Scraper Large	\$ 294.00	\$ -
	Single Axle	\$ 51.00	\$ -		Scraper Small	\$ 190.00	\$ -
	Excavator Small	\$ 145.00	\$ -		Haul Truck	\$ 226.00	\$ -
	Excavator Large	\$ 189.00	\$ -	8	Roller Pad / Smooth	\$ 93.00	\$ 744.00
	Excavator Mini	\$ 105.00	\$ -		Compactor - 815	\$ 195.00	\$ -
	Skid Steer	\$ 87.00	\$ -		GPS for Dozer or Grader	\$ 33.00	\$ -
	Loader Small	\$ 118.00	\$ -	8	Dozer	\$ 102.00	\$ 816.00
	Loader Large	\$ 155.00	\$ -		Misc -	\$ -	\$ -
<b>TOTAL DIRECT EQUIPMENT:</b>							<b>\$ 2,020.00</b>

TOTALS					
TOTAL LABOR + Markup	10%	\$ 2,668.34	TOTAL SUBS +	10%	\$ -
TOTAL MATERIAL + Markup	10%	\$ 470.80	TOTAL GL Insurance (per Thousand)	\$ 18.481	\$ 44.83
TOTAL EQUIPMENT + Markup	10%	\$ 2,222.00	TOTAL Workmans Comp (per Hundred)	\$ 3.88	\$ 94.12
<b>PAGE SUB-TOTAL</b>					<b>\$ 5,500.09</b>
<b>ALLOWABLE PROFIT</b>					<b>\$ -</b>
<b>TOTAL WITH PROFIT</b>					<b>\$ 5,500.09</b>

CONTRACTOR'S APPROVAL / prepared by:  
Parker Smith

Quantity: 1 ls  
Unit Price: \$ 5,500.09

# JOHN HALL CONSTRUCTION, INC.

---

6448 S. COUNTY ROAD 675 E • PLAINFIELD, INDIANA 46168-8655

PHONE: (317) 839-0318

FAX: (317) 839-3000

September 6, 2023

Mr. Jay Jeffries  
Patterson Horth General Contractors  
5745 Progress Road  
Indianapolis, IN 46241

PROJECT: Danville Water Treatment Plant  
Danville, Indiana

Dear Mr. Jeffries,

Request for change in the amount of: **\$12,460.00**

Build the sub-grade on the walk path west of Columbia Street Drawing Sheet #100 (date 8/23/23)	<b>\$12,460.00</b>
---	--------------------

Respectfully Submitted,

Jon Payne  
Construction Manager





**PATTERSON HORTH**  
GENERAL CONTRACTORS

Change Order Request #09

TITLE: Unsuitable Soils at Loop Drive

DATE: 1/10/2024

PROJECT: Danville WTP

PROJECT # 22232

TO: Banning Engineering

DESCRIPTION OF PROPOSAL							
Soft/Unsuitable soils were encountered per the attached Alt Witzig proofroll inspection report at main loop drive/road around new WTP. Per the discussions and direction of Alt Witzig and Banning Engineering we all agreed to proceed with the previously approved/established unit pricing for the additional excavation, geogrid, stone backfill, trucking/removal/disposal offsite at Owner provided dumpsite. The unit prices are inclusive of all markups, equipment, labor, material, etc. (#53 Stone \$75/Ton).							
ITEM#	DESCRIPTION	QUANTITY	UNIT	UNIT PRICE	TOTAL		
1.	Area 1 - 26'x95'x1.17'	158.94	TN	\$ 75.00	\$	11,921	
2.	Area 2 - 10'x15'x1.17'	9.65	TN	\$ 75.00	\$	724	
3.	Area 3 - 10'x23'x1.17'	14.80	TN	\$ 75.00	\$	1,110	
4.	Area 4 - 16'x25'x1.17'	25.74	TN	\$ 75.00	\$	1,931	
5.	Area 5 - 9'x60'x1.17'	34.75	TN	\$ 75.00	\$	2,606	
6.	Area 6 - 45'x45'x2'	222.75	TN	\$ 75.00	\$	16,706	
7.	Geo-Grid	2	rolls	\$ 960.00	\$	1,920	
					\$	-	
						Self Perform Subtotal	\$ 36,918
						Subtotal	\$ 36,918
						Self Perform PH FEE (15%)	INCLUDED
						Subcontractor PH FEE (5%)	INCLUDED
						Bonds & Insurance (1.25%)	INCLUDED
						Total Add	\$ 36,918

**Patterson Horth, Inc.**  
5745 Progress Drive  
Indianapolis, Indiana 46241  
p: 317-243-6104  
f: 317-243-6398



# Alt & Witzig Engineering, Inc.

4105 West 99th Street • Carmel, IN 46032  
(317) 875-7040 • Fax (800) 875-6028

---

**Inspection Date:** Wednesday, November 29, 2023

**Tested For:**

Mr. Jim Alstatt  
Patterson Horth, Inc.  
5745 Progress Drive  
Indianapolis, IN 46241

**Project:**

Danville WTP - PO#22232  
Danville, IN  
A&W Project:TD23002

## PROOFROLL INSPECTION

As per your request, our Senior Project Manager arrived at the above referenced jobsite to observe the present site soil conditions. These observations were limited to the soil subgrade for the proposed drive around the building.

To assist in our observations, a proofroll was conducted. A loaded tri-axle dump truck was utilized for the proofrolling operation. The truck was driven across the subgrade at a slow rate of speed. During this process, the subgrade was closely monitored for any indications of soft or unstable materials. The results indicated soft and unstable materials in six (6) locations. The areas were field marked for reference and are included on the attached diagram. The approximate locations and sizes are as follows:

- 1) South Entrance; 26' by 95'
- 2) Southeast Corner; 10' by 15'
- 3) East Side; 10' by 23'
- 4) Northeast Corner; 16' by 25'
- 5) North Side; 9' by 60'
- 6) North Entrance; 45' by 45' (Widest Dimension)

### Areas 1-5

We recommend the exposed unstable subgrade areas be stabilized prior to the placement of the proposed crushed stone and asphalt section utilizing a geogrid mat and thickened stone subbase. The subgrade will require undercutting to allow for the installation of the proposed additional stone base materials and geogrid mat. We recommend the depth of the undercut to be a minimum of fourteen (14) inches.

Numerous projects have utilized geogrid mat systems to stabilize soft soil conditions. The geogrid (Tensar BX1200 or equivalent) should be placed over the materials at the base of the undercut.

- The grid should be installed at the base of the undercut per the manufacturer's recommendations.



- Following installation of the geogrid, it is recommended that INDOT #53 crushed stone be placed over the grid and compacted per the project plans and specifications.
- The stone should be installed by back dumping the material at the edge of the geogrid and spreading the stone over the grid using a dozer or similar type equipment.
- **Do not allow any equipment to run directly on the geogrid.**
- No heavy traffic (trucks) shall be allowed across the grid area until a minimum covering of twelve (12) inches of stone is in place.

#### Area 6

Because of the soil conditions observed during our site visit, it is recommended that the area of soft and unstable materials in Area 6 be undercut by a minimum of twenty-four (24) inches below the design subgrade elevation. Upon removal, it is suggested to place a layer of #2 crushed limestone at the base of the undercut and "punch" the stone into the soils at the base of the undercut. Following the placement and consolidation of the #2 crushed limestone, it is recommended that the remainder of the undercut be re-established utilizing a geogrid mat such as Tensar BX1200 or equivalent, and INDOT #53 crushed limestone. The geogrid mat should be installed per the manufacturer's recommendations. The INDOT #53 crushed limestone should be placed and compacted in accordance with the project plans and specifications.

If you have any questions concerning this report, please contact our office at your convenience.

**Sr. Project Manager:** Yohansen M. Losey



**Diagram**

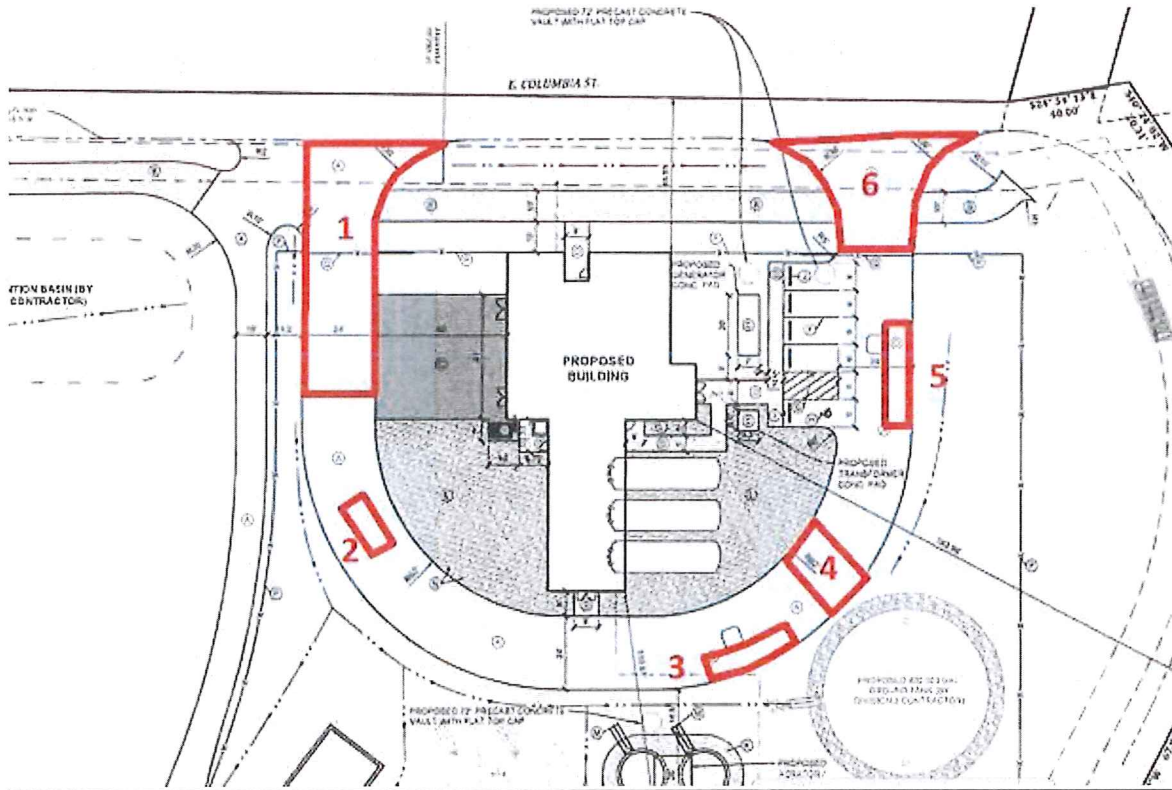

Approximate locations of soft and unstable materials



**PATTERSON HORTH**  
GENERAL CONTRACTORS

Change Order Request #10

TITLE: Duct Insulation

DATE: 1/31/2024

PROJECT: Danville WTP

PROJECT # 22232

TO: Banning Engineering

DESCRIPTION OF PROPOSAL								
COR is to provide duct insulation for above ceiling duct work per RFI #41...								
ITEM#	DESCRIPTION				QUANTITY	UNIT	UNIT PRICE	TOTAL
							Material/Equipment Total	\$ -
							Self Perform Labor Subtotal	\$ -
1.	Koehring & Sons, Inc.				1	LS	\$ 1,680.00	\$ 1,680
								\$ -
							Subcontractor Subtotal	\$ 1,680
							Subtotal	\$ 1,680
							SP Labor & Material PH FEE (15%)	\$ -
							Subcontractor PH FEE (5%)	\$ 84
							Bonds & Insurance (1.25%)	\$ 22
							Total Add	\$ 1,786

**Patterson Horth, Inc.**  
5745 Progress Drive  
Indianapolis, Indiana 46241  
p: 317-243-6104  
f: 317-243-6398

**Koehring & Sons, Inc.**  
**(317) 639-6541**  
**153 Bethel Ave.**  
**Beech Grove, IN 46107**

**To: Patterson Horth, Inc.**  
**5745 Progress Dr.**  
**Indianapolis, IN 46241**  
**ATTN: Jim Alstatt**

<b>CO #: 2</b>
<b>Project: Danville WTP Div. 2, IN</b>
<b>Project Number: 22-023</b>
<b>Date: 01/29/2024</b>

<b>To furnish and install.</b> <b>1 – Lot Duct Insulation &amp; Labor</b>	<b>Total: \$1,680.00</b>
<b>Note: This change order becomes part of and in conformance with the existing contract.</b>	

Authorized Signature: *Eric A. Koehring* **EAK**

Accepted - The above prices and specifications of this change order are satisfactory and are hereby accepted. All work to be performed under same terms and conditions as specified in the original contract unless otherwise.

Date of Acceptance: \_\_\_\_\_

Signature: \_\_\_\_\_



**PATTERSON HORTH**  
GENERAL CONTRACTORS

Change Order Request #13REV1

TITLE: DIV 4 FINAL QUANTITIES

DATE: 6/14/2024

PROJECT: Danville WTP

PROJECT # 22232

TO: Banning Engineering

DESCRIPTION OF PROPOSAL

See attached DIV 4 worksheet for details on installed pipe and fittings.

ITEM#	DESCRIPTION	QUANTITY	UNIT	UNIT PRICE	TOTAL
1.	Division 4 Total Base Bid Bid Amount	-1.00	LS	\$ 1,558,135.00	\$ (1,558,135)
2.	Division 4 Total Adjusted Bid Amount based on Final Installed Quantities	1.00	LS	\$ 1,619,254.20	\$ 1,619,254
					\$ -
					\$ -
					\$ -
					\$ -
					\$ -
					\$ -
					\$ -
				<b>Subtotal</b>	<b>\$ 61,119</b>
				<b>Subtotal</b>	<b>\$ 61,119</b>
				<b>Self Perform PH FEE (15%)</b>	<b>INCLUDED</b>
				<b>Subcontractor PH FEE (5%)</b>	<b>INCLUDED</b>
				<b>Bonds &amp; Insurance (1.25%)</b>	<b>INCLUDED</b>
				<b>Total Add</b>	<b>\$ 61,119</b>

**Patterson Horth, Inc.**  
5745 Progress Drive  
Indianapolis, Indiana 46241  
p: 317-243-6104  
f: 317-243-6398

COR #13 QUANTITIES ADJUSTMENT

Item No.	Description	Quantity	Unit	Bid		PH Quantities		Bidding Quantities	
				Unit Price	Amount	Units	Amount	Units	Amount
1	MOBILIZATION/DEMOLITION	1	LS	\$ 120,034.00	\$ 120,034.00	1	\$ 120,034.00	1	\$ 120,034.00
2	EROSION CONTROL	1	LS	\$ 34,331.00	\$ 34,331.00	1	\$ 34,331.00	1	\$ 34,331.00
3	TRAFFIC CONTROL	1	LS	\$ 126,286.00	\$ 126,286.00	1	\$ 126,286.00	1	\$ 126,286.00
4	8" CL 350 DUCTILE IRON, ZINC COATED, RAW WATER MAIN, OPEN CUT	20	LF	\$ 2,460.00	\$ 49,200.00	20	\$ 4,920.00	40	\$ 9,840.00
5	8" DIMJ 45 DEG BEND	1	EACH	\$ 762.00	\$ 762.00	4	\$ 3,048.00	4	\$ 3,048.00
6	8" DIMJ 90 DEG BEND	2	EACH	\$ 845.00	\$ 1,690.00	2	\$ 1,690.00	1	\$ 845.00
7	8" DIMJ CAP	3	EACH	\$ 515.00	\$ 1,545.00	4	\$ 2,060.00	4	\$ 2,060.00
8	8" DIMJ COUPLING	3	EACH	\$ 762.00	\$ 2,286.00	0	\$ -	0	\$ -
9	8" GATE VALVE AND VALVE BOX ASSEMBLY	2	EACH	\$ 3,165.00	\$ 6,330.00	2	\$ 6,330.00	2	\$ 6,330.00
10	12" CL 350 DUCTILE IRON, ZINC COATED, WATER MAIN, OPEN CUT	960	LF	\$ 141.00	\$ 135,360.00	728	\$ 102,848.00	855	\$ 120,355.00
11	12" CL 350 DUCTILE IRON, ZINC COATED, WATER MAIN, DIRECTIONAL DRILLED	420	LF	\$ 307.00	\$ 128,940.00	0	\$ -	0	\$ -
12	12" DIMJ 11.25 DEG BEND	1	EACH	\$ 1,357.00	\$ 1,357.00	0	\$ -	0	\$ -
13	12" DIMJ 45 DEG BEND	1	EACH	\$ 1,642.00	\$ 1,642.00	4	\$ 6,568.00	4	\$ 6,568.00
14	12" DIMJ 90 DEG BEND	1	EACH	\$ 1,710.00	\$ 1,710.00	1	\$ 1,710.00	1	\$ 1,710.00
15	12" X 12" DIMJ TEE	4	EACH	\$ 2,330.00	\$ 9,320.00	3	\$ 6,990.00	3	\$ 6,990.00
16	12" X 12" STAINLESS STEEL TAPPING TEE AND WET TAP CONNECTION TO EXISTING MAIN	1	EACH	\$ 14,713.00	\$ 14,713.00	1	\$ 14,713.00	0	\$ -
17	12" GATE VALVE AND VALVE BOX ASSEMBLY	7	EACH	\$ 8,583.00	\$ 60,081.00	6	\$ 48,742.00	7	\$ 60,081.00
18	12" X 8" DIMJ REDUCER	3	EACH	\$ 1,104.00	\$ 3,312.00	3	\$ 3,312.00	3	\$ 3,312.00
19	12" DIMJ CAP	2	EACH	\$ 757.00	\$ 1,514.00	2	\$ 1,514.00	2	\$ 1,514.00
20	16" HDPE DR11 PE4710, RAW WATER MAIN, DIRECTIONAL DRILLED	460	LF	\$ 261.00	\$ 120,060.00	1220	\$ 318,420.00	1180	\$ 302,760.00
21	16" CL 350 DUCTILE IRON, ZINC COATED, WATER MAIN, OPEN CUT	1220	LF	\$ 252.540	\$ 307,100.00	1220	\$ 307,100.00	1235	\$ 312,555.00
22	20" HDPE DR11 PE4710, RAW WATER MAIN, DIRECTIONAL DRILLED	260	LF	\$ 541.00	\$ 140,660.00	300	\$ 162,300.00	235	\$ 128,625.00
23	16" X 12" DIMJ REDUCER	2	EACH	\$ 2,146.00	\$ 4,292.00	6	\$ 12,876.00	6	\$ 12,876.00
24	16" X 12" DIMJ TEE	1	EACH	\$ 3,679.00	\$ 3,679.00	1	\$ 3,679.00	1	\$ 3,679.00
25	16" GATE VALVE AND VALVE BOX ASSEMBLY	1	EACH	\$ 14,799.00	\$ 14,799.00	1	\$ 14,799.00	1	\$ 14,799.00
26	16" DIMJ 11.25 DEG BEND	1	EACH	\$ 2,545.00	\$ 2,545.00	5	\$ 12,725.00	5	\$ 12,725.00
27	16" DIMJ 90 DEG BEND	1	EACH	\$ 3,424.00	\$ 3,424.00	1	\$ 3,424.00	1	\$ 3,424.00
28	16" DIMJ CAP	2	EACH	\$ 1,516.00	\$ 3,032.00	1	\$ 1,516.00	1	\$ 1,516.00
29	1-1/2" HDPE DR11 PE4710, FORCE MAIN, OPEN CUT	1200	LF	\$ 36.00	\$ 43,200.00	1200	\$ 43,200.00	1110	\$ 39,960.00
30	1-1/2" HDPE DR11 PE4710, FORCE MAIN, DIRECTIONAL DRILLED	200	LF	\$ 54.00	\$ 10,800.00	200	\$ 10,800.00	186	\$ 10,044.00
31	6" DR18 C900 PVC FORCE MAIN, OPEN CUT	1200	LF	\$ 80.00	\$ 96,000.00	1200	\$ 96,000.00	1110	\$ 88,800.00
32	10" HDPE DR11 PE4710, DIRECTIONALLY DRILLED, FORCE MAIN	200	LF	\$ 233.00	\$ 46,600.00	200	\$ 46,600.00	186	\$ 43,338.00
33	CONNECTION TO EXISTING SANITARY STRUCTURES	2	EACH	\$ 920.00	\$ 1,840.00	2	\$ 1,840.00	2	\$ 1,840.00
34	LOCATION WIRE	16000	LF	\$ 0.61	\$ 9,760.00	16000	\$ 9,760.00	17940	\$ 10,943.40
35	12" ADS HP STORM PIPE	830	LF	\$ 62.00	\$ 51,460.00	888	\$ 55,056.00	888	\$ 55,056.00
36	24" X 24" STORM INLET	6	EACH	\$ 3,780.00	\$ 22,680.00	6	\$ 22,680.00	6	\$ 22,680.00
37	48" DIAMETER STORM MANHOLE	1	EACH	\$ 6,744.00	\$ 6,744.00	1	\$ 6,744.00	1	\$ 6,744.00
38	12" CONCRETE END SECTION	1	EACH	\$ 2,207.00	\$ 2,207.00	1	\$ 2,207.00	1	\$ 2,207.00
39	STORM STRUCTURE 108	1	EACH	\$ 9,809.00	\$ 9,809.00	1	\$ 9,809.00	1	\$ 9,809.00
40	3" ID DR11 PE4710 ELECTRIC CONDUIT, DIRECTIONALLY DRILLED	600	LF	\$ 67.00	\$ 40,200.00	600	\$ 40,200.00	600	\$ 40,200.00
41	2" ID DR11 PE4710 ELECTRIC CONDUIT, DIRECTIONALLY DRILLED	300	LF	\$ 40.00	\$ 12,000.00	300	\$ 12,000.00	300	\$ 12,000.00
42	LOW PRESSURE SEWER LATERAL CONNECTION	1	LS	\$ 6,131.00	\$ 6,131.00	2	\$ 12,262.00	2	\$ 12,262.00
43	20" X 16" DIMJ REDUCER	2	LS	\$ 2,610.00	\$ 5,220.00	2	\$ 5,220.00	2	\$ 5,220.00
44	16" X 12" SIDEWALL FUSION	0	LS	\$ 6,626.00	\$ 0.00	1	\$ 6,626.00	1	\$ 6,626.00
45	12" CL 350 DUCTILE IRON, ZINC COATED, WATER MAIN, MATERIAL ONLY	0	LS	\$ 64.19	\$ 0.00	0	\$ -	220	\$ 14,121.80
TOTAL BID AMOUNT				\$	1,558,135.00	\$	1,645,719.86	\$	1,619,254.20
					Difference from Bid		\$ 87,584.86		\$ 61,119.20
							Difference from PH		\$ (26,465.66)







**PATTERSON HORTH**  
GENERAL CONTRACTORS

Change Order Request #14

TITLE: Well 05 Electrical Service

DATE: 5/17/2024

PROJECT: Danville WTP

PROJECT # 22232

TO: Banning Engineering

DESCRIPTION OF PROPOSAL

Well 05 required new electrical service. Below is the cost for installing required earth fill to elevate transformer area and install transformer concrete pad all per Duke Energy requirements attached. Danville also requested stone within the fence perimeter at well 05 and 06.

ITEM#	DESCRIPTION	QUANTITY	UNIT	UNIT PRICE	TOTAL
1.	Concrete Labor to Form, Pour, Wreck and Cleanu	35	MH	\$ 55.00	\$ 1,925.00
				<b>Self Perform Labor Total</b>	\$ 1,925.00
2.	Concrete Materials	1	LS	\$ 854.00	\$ 854.00
3.	Concrete Equipment	1	LS	\$ 1,177.00	\$ 1,177.00
				<b>Self Perform Material/Equipment Total</b>	\$ 2,031.00
4.	John Hall - Earthwork	1	LS	\$ 3,140.00	\$ 3,140
5.	Williams Creek - #8 Stone at Well 05 & 06	1	LS	\$ 3,804.00	\$ 3,804
					\$ -
				<b>Subcontractor Subtotal</b>	\$ 6,944
				<b>Subtotal</b>	\$ 10,900
				<b>SP Labor &amp; Material PH FEE (15%)</b>	\$ 593
				<b>Subcontractor PH FEE (5%)</b>	\$ 347
				<b>Bonds &amp; Insurance (1.25%)</b>	\$ 148
				<b>Total Add</b>	\$ 11,989

**Patterson Horth, Inc.**  
5745 Progress Drive  
Indianapolis, Indiana 46241  
p: 317-243-6104  
f: 317-243-6398

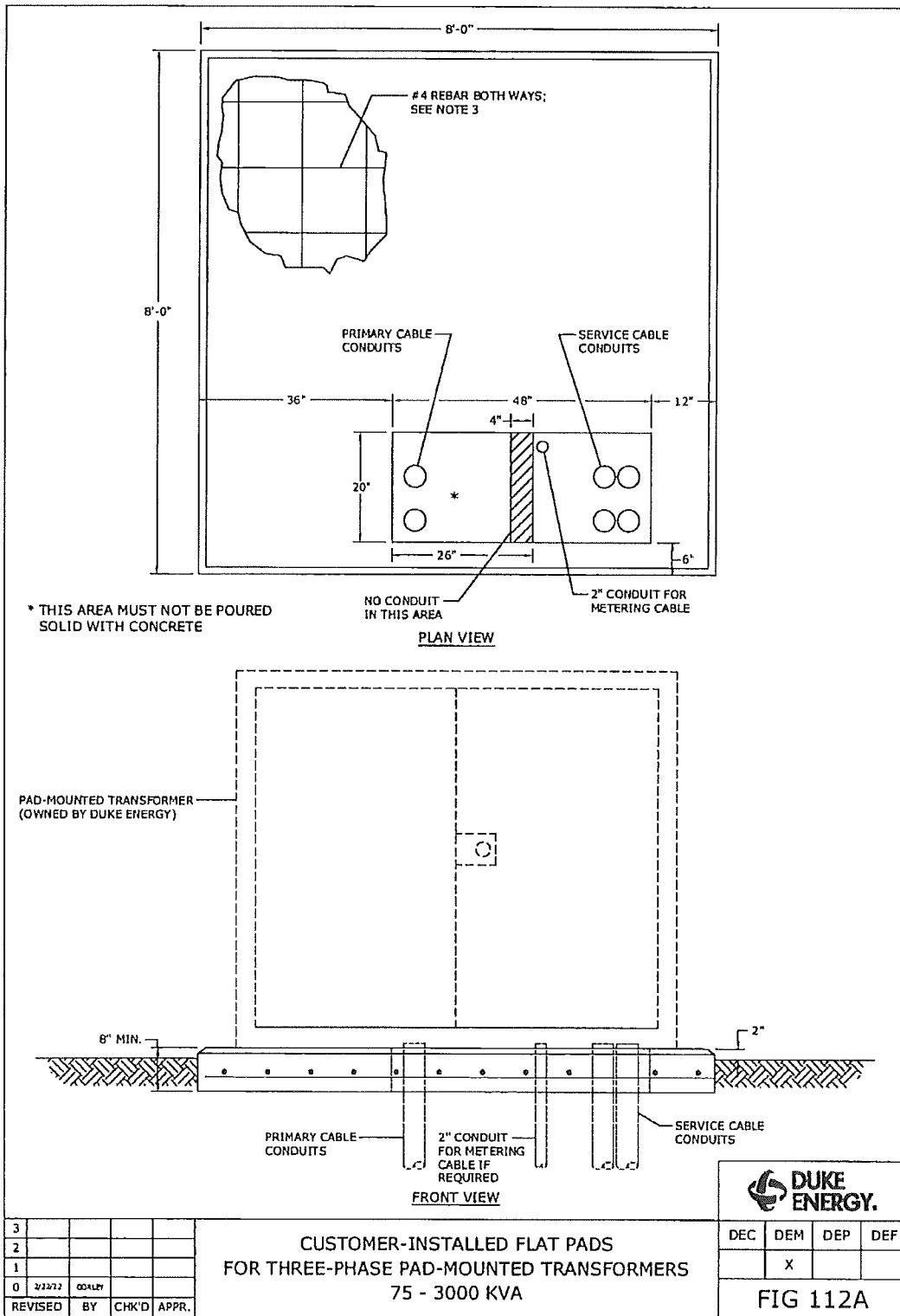

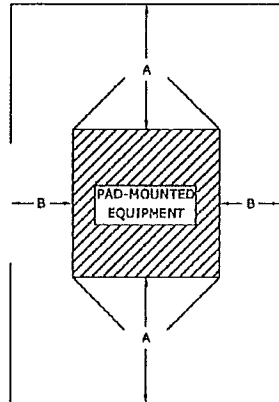

MINIMUM CLEAR WORKING SPACE AROUND PAD-MOUNTED EQUIPMENT		
TYPE OF PAD-MOUNTED EQUIPMENT	DIMENSION A DOOR SIDES (FT)	DIMENSION B (FT)
TRANSFORMERS (SEE NOTE 4)	10	3
SWITCHGEAR (SEE NOTE 3)	10	5
RECLOSERS, PRIMARY METERS, ETC.	10	3

MISCELLANEOUS CLEARANCES	
TYPE OF EQUIPMENT	CLEARANCE IN ANY DIRECTION (FT)
FUEL OR GAS DISPENSERS	20
CONTAINERS STORING FLAMMABLE LIQUID OR GAS	10
CUSTOMER-OWNED GENERATORS OR TRANSFORMERS	10
FIRE HYDRANTS	SEE NOTE 6
NATURAL GAS METERS	3

**NOTES:**

1. ADEQUATE PASSAGeways TO ACCOMMODATE CRANES, LINE TRUCKS, OR OTHER NECESSARY LIFTING AND HAULING EQUIPMENT SHALL BE PROVIDED TO ALLOW FOR MAINTENANCE, OPERATION, OR REPLACEMENT.
2. DISTANCES ARE FROM THE PAD OR SURFACE MOUNTED EQUIPMENT, WHICHEVER IS CLOSER TO THE OBJECT IN QUESTION.
3. A MINIMUM CLEAR WORKING SPACE OF 5 FT MUST BE MAINTAINED FROM EACH NON-DOOR SIDE OF THE EQUIPMENT (TO ACCOMMODATE CONTROL CABINETS, ETC.).
4. WHERE A METER IS MOUNTED TO A TRANSFORMER, A CLEAR SPACE AROUND THE METER OF AT LEAST 3 FT WIDE, 4 FT DEEP, AND 8 FT HIGH MUST BE PROVIDED AND ALWAYS AVAILABLE FOR READING, INSPECTING, TESTING, AND MAINTENANCE OPERATIONS.
5. DISTANCES LESS THAN THOSE SPECIFIED MAY BE ALLOWED IF APPROVED BY THE APPROPRIATE CODE ENFORCEMENT AUTHORITY. THIS MAY REQUIRE ALTERNATE MEANS OF FIRE PROTECTION INCLUDING FIRE BARRIERS, FIRE RATED WALLS, SPRINKLER SYSTEMS, OIL CONTAINMENT MEANS, OR OTHER APPROVED MEASURES.
6. 4 FT, MAY BE REDUCED TO 3 FT BY AGREEMENT WITH LOCAL FIRE AUTHORITY.



3					
2					
1					
0	2/11/19	DELETED	BAUWS	ASDCR	
REVISED	BY	CK'D	APPR.		

**PAD-MOUNTED EQUIPMENT WORKING SPACE  
AND MISCELLANEOUS CLEARANCES**

DEC	DEM	DEP	DEF
	X		
FIG 121			

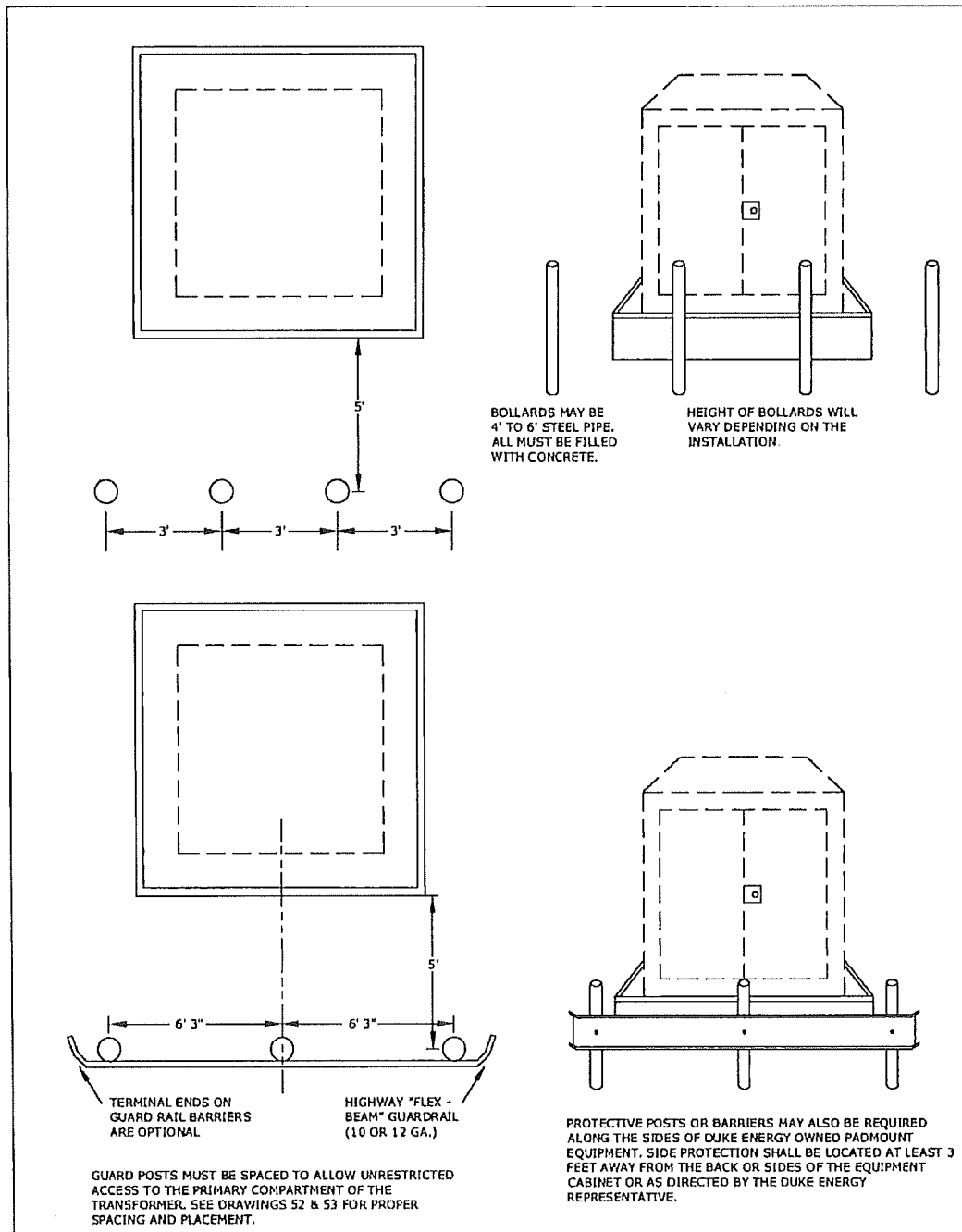

SEE FIGURE 122B FOR BOLLARD DETAILS AND NOTES

**DUKE ENERGY.**

DEC	DEM	DEP	DEF
	X		

**FIG 122A**

3				
2				
1				
0	7/12/13	DEF/BLB	BR/UMS	AD/OD/C
REVISED	BY	CK'D	APPR.	

**CONSTRUCTION DETAILS FOR PROTECTING PAD-MOUNTED EQUIPMENT**

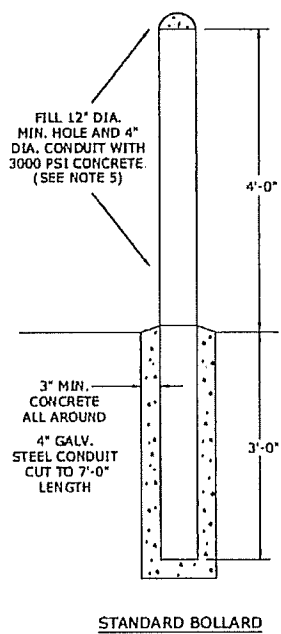
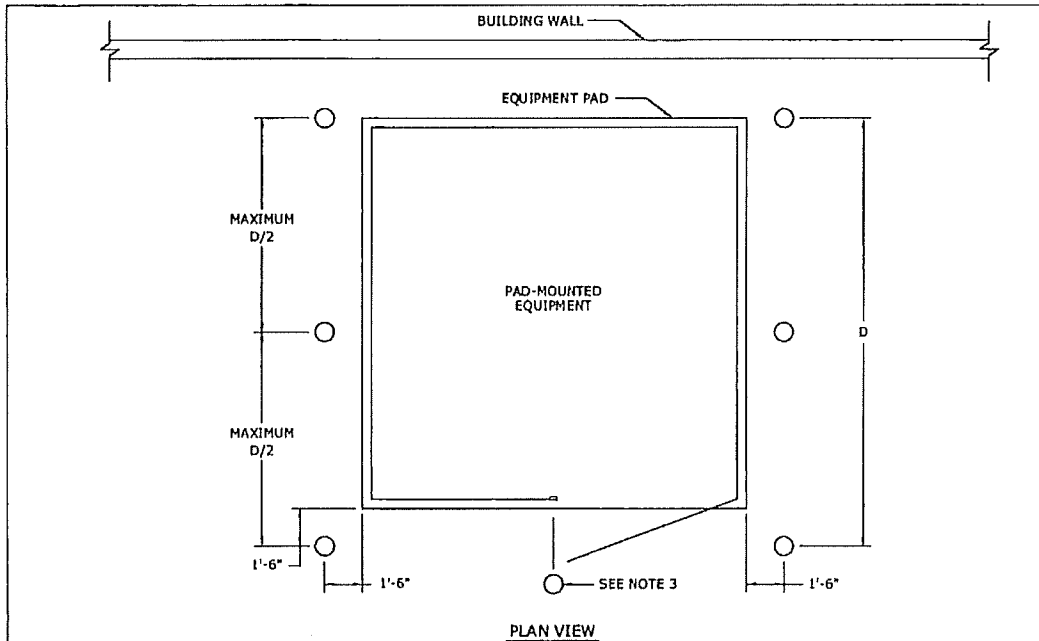

- NOTES:**
1. PROTECTIVE POLES CAN BE INSTALLED ON ALL SIDES OF PAD-MOUNTED EQUIPMENT THAT ARE SUBJECT TO REGULAR VEHICLE TRAFFIC. THEIR USE IS AT THE DISCRETION OF LOCAL ENGINEERING AND WILL BE THE CUSTOMER'S RESPONSIBILITY TO PROVIDE AND INSTALL AFTER ALL REASONABLE EFFORTS TO LOCATE THE PAD-MOUNTED EQUIPMENT ELSEWHERE HAVE BEEN EXHAUSTED.
  2. POLES SHOULD BE EVENLY SPACED ALONG THE SIDES OF THE PAD-MOUNTED EQUIPMENT, NO WIDER THAN HALF THE DIMENSION OF THE SIDE THEY ARE PROTECTING. EXCEPTIONS TO THIS ALONG SIDES WITH DOORS ARE ALLOWED IN ORDER TO ACCOMMODATE NOTE 3.
  3. ON ANY SIDE OF PAD-MOUNTED EQUIPMENT WITH DOORS, THIS POLE SHOULD BE CENTRALLY LOCATED BETWEEN THE DOORS AND MUST ACCOMMODATE THE DOOR SWING OF THE EQUIPMENT. IT SHALL BE EITHER REMOVABLE OR COLLAPSIBLE. REMOVABLE OR COLLAPSIBLE DESIGNS OTHER THAN WHAT ARE SHOWN MUST BE APPROVED BY LOCAL ENGINEERING.
  4. POLES LOCATED ON ANY SIDE OF PAD-MOUNTED EQUIPMENT SHALL NOT INTERFERE WITH THE SAFE OPERATION AND EXPECTED MAINTENANCE OR REPLACEMENT OF THAT EQUIPMENT.
  5. POLES SHALL BE PAINTED YELLOW OR OUTFITTED WITH A YELLOW BOLLARD COVER OR POST SLEEVE.
  6. ALL POLES SHALL HAVE A 2" REFLECTIVE TAPE APPLIED EITHER AROUND THE TOP OF THE BOLLARD OR EXTENDING VERTICALLY DOWN THE LENGTH OF THE BOLLARD FOR 24". VERTICAL APPLICATIONS MUST BE ON THE SIDE FACING ANY ANTICIPATED TRAFFIC.

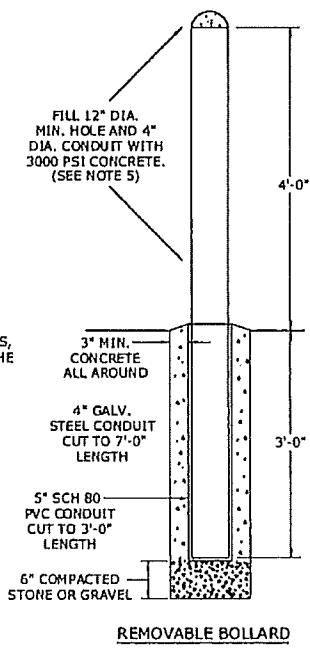

3				
2				
1	3/20/19	DETAILS	RUN/MS	ADD/OK
0	2/7/19	DETAILS	RUN/MS	ADD/OK
REVISED	BY	CK'D	APPR.	

PROTECTIVE BOLLARD (FIXED AND REMOVABLE) DETAILS AND NOTES

**DUKE ENERGY.**

DEC	DEM	DEP	DEF
	X		

**FIG 122B**

# JOHN HALL CONSTRUCTION, INC.

6448 S. COUNTY ROAD 675 E • PLAINFIELD, INDIANA 46168-8655

PHONE: (317) 839-0318

FAX: (317) 839-3000

## Request For Change

~~Jacob~~  
Jay  
Jeffries

Danville Division I

May 9, 2024

Request For Change

\$ 3,140.00

Well #5

Build Transformer Pad and Extend Pad on East Side of the Well

Thank you,

Jon Payne, Estimator

**Jim Alstatt**

---

**From:** Hunter Mason  
**Sent:** Wednesday, May 15, 2024 9:15 AM  
**To:** Jim Alstatt; Jay Jeffries  
**Subject:** Fwd: Danville WTP Stone Install

Fyi

Hunter Mason | Superintendent

Patterson Horth, Inc.

5745 Progress Road | Indianapolis, IN 46241

o 317.243.6104 | c 317.919.7241  
hmason@pattersonhorth.com  
www.pattersonhorth.com

---

**From:** Beau Green <bgreen@williamscreekmgt.net>  
**Sent:** Wednesday, May 15, 2024 9:14:08 AM  
**To:** Hunter Mason <hmason@pattersonhorth.com>  
**Cc:** Nic Steadman <nsteadman@williamscreekmgt.net>  
**Subject:** Danville WTP Stone Install

Hunter,

Below is a price estimate for 700 SF of #8 stone installed with filter fabric. Thanks.

DESCRIPTION	QUANTITY	UNIT	UNIT COST	TOTAL COST
Fabric/#8 Stone Installation	1	LS	\$3,804.00	\$3,804.00



**Beau Green**  
Crew Foreman - Installation  
bgreen@williamscreekmgt.net  
(765) 720-4113

[\(317\) 838-9810](tel:(317)838-9810)  
 <https://www.williamscreekmgt.com/>  
 4620 S Country Road 600 E, Plainfield, IN 46168

# ORDINANCE 18 - 2024

## An Ordinance to amend Ordinance 2 - 2024 "2024 Salaries and Other Compensation for Officials, Employees and Appointees of the Town of Danville".

**Whereas**, the Danville Town Council approved and adopted Ordinance 2 - 2024 which established wages and salaries of employees of the Town of Danville;

**Whereas**, the salary ordinance needs amended to add Section 18: Full-Time Civilian Medic Stipend effective September 6, 2024 pay date and add the position of FF/Medic – 3 Year;

**Whereas**, the Wage & Salary Section can be amended.

**Now, Therefore**, be it ordained that Ordinance 18 - 2024 be amended as follows:

**The Town will provide each Full-Time Civilian Medic with a \$2,000 annual stipend, this will be prorated for the current year.**

DEPARTMENT	POSITION	WAGE/SALARY	PAY TYPE	FUNDING
Fire	FF/Medic (1) – 3 Year	\$2,769.24	BI-WEEKLY SALARY	GENERAL

So approved this 21<sup>st</sup> day of August, 2024.

TOWN OF DANVILLE

\_\_\_\_\_  
Christopher Gearld

Attest:

\_\_\_\_\_  
Carrie E Lofton, Clerk – Treasurer

\_\_\_\_\_  
Michael Chatham

\_\_\_\_\_  
Gregory Irby

\_\_\_\_\_  
Bret Doub

\_\_\_\_\_  
David Potter



**ORDINANCE NO. 19-2024**  
**ADDITIONAL APPROPRIATION**

WHEREAS the proper officers of the Danville Town Council of Town of Danville,  
 (Adopting Body) (Taxing Unit)

Hendricks County, Indiana have determined that it is now necessary to appropriate more  
 (Name of County)

money for calendar year 2024 than the amount that was fixed by the Danville Town Council  
 (Year) (Adopting Body)

and finally determined in the annual budget under Indiana Code 6-1.1; and

WHEREAS notice was duly given to the public in accordance with IC 6-1.1-18-5(a) and IC 5-3-1-2(b)

for a public hearing on a proposed additional appropriation and a public hearing was held on

August 21, 2024, by the Danville Town Council regarding the  
 same: (Date) (Year) (Adopting Body)

THEREFORE, BE IT ORDAINED (RESOLVED) by the Danville Town Council of  
 (Adopting Body)

Town of Danville, Hendricks County, Indiana that a need now exists for an additional  
 (Taxing Unit) (Name of County)

appropriation out of the following fund or funds named, and for the purposes specified, subject to laws governing the same:

<b>FUND INFORMATION</b>		
Fund Name: EDIT – Economic Development Income Tax Credit		
<b>Budget Classification</b>	<b>Additional Amount Requested</b>	<b>Additional Amount Adopted</b>
Personal Services	\$	\$
Supplies	\$	\$
Other Services and Charges	\$7,000	\$7,000
Township Assistance	\$	\$
Debt Service	\$	\$
Capital Outlays	\$	\$
<b>Total:</b>	<b>\$7,000</b>	<b>\$7,000</b>

Duly adopted by the following vote of the members of said Danville Town Council this 21st  
 (Adopting Body)  
 day of August, 2024.

ADOPTION INFORMATION			
Official Vote		Name	Signature
Nay	Aye		
<input type="checkbox"/>	<input type="checkbox"/>	Christopher Gearld	
<input type="checkbox"/>	<input type="checkbox"/>	Michael Chatham	
<input type="checkbox"/>	<input type="checkbox"/>	Gregory Irby	
<input type="checkbox"/>	<input type="checkbox"/>	Bret Doub	
<input type="checkbox"/>	<input type="checkbox"/>	David Potter	

<b>Attestation by Secretary of Governing Body</b>	
<b>Date</b>	



## UNIFORM CONFLICT OF INTEREST DISCLOSURE STATEMENT

State Form 54266 (R2 / 6-15) / Form 236  
STATE BOARD OF ACCOUNTS

### Indiana Code 35-44.1-1-4

A public servant who knowingly or intentionally has a pecuniary interest in or derives a profit from a contract or purchase connected with an action by the governmental entity served by the public servant commits conflict of interest, a Class D Felony. A public servant has a pecuniary interest in a contract or purchase if the contract or purchase will result or is intended to result in an ascertainable increase in the income or net worth of the public servant or a dependent of the public servant. "Dependent" means any of the following: the spouse of a public servant; a child, stepchild, or adoptee (as defined in IC 31-9-2-2) of a public servant who is unemancipated and less than eighteen (18) years of age; and any individual more than one-half (1/2) of whose support is provided during a year by the public servant.

The foregoing consists only of excerpts from IC 35-44.1-1-4. Care should be taken to review IC 35-44.1-1-4 in its entirety.

1. **Name and Address of Public Servant Submitting Statement:** Corey Caylor  
594 W. Main Street, Danville, IN 46122
2. **Title or Position With Governmental Entity:** Reserve Police Officer
3. a. **Governmental Entity:** Town of Danville, IN  
b. **County:** Hendricks
4. **This statement is submitted (check one):**
  - a.  as a "single transaction" disclosure statement, as to my financial interest in a specific contract or purchase connected with the governmental entity which I serve, proposed to be made by the governmental entity with or from a particular contractor or vendor; or
  - b.  as an "annual" disclosure statement, as to my financial interest connected with any contracts or purchases of the governmental entity which I serve, which are made on an ongoing basis with or from particular contractors or vendors.
5. **Name(s) of Contractor(s) or Vendor(s):** Consolidated Solutions, LLC,  
Caylor Communications, Inc., One Choice Technology, Priority Outfitters,  
Priority Push-to-Talk
6. **Description(s) of Contract(s) or Purchase(s)** *(Describe the kind of contract involved, and the effective date and term of the contract or purchase if reasonably determinable. Dates required if 4(a) is selected above. If "dependent" is involved, provide dependent's name and relationship.):*  
IT Services, Telephony & Communications Equipment & Services, Vehicle Equipment & Maintenance, Vending & ATM Services  
(All services ongoing, either directly with or secondary to this servant's involvement with the Town of Danville, IN)  
\_\_\_\_\_  
\_\_\_\_\_  
\_\_\_\_\_

7. **Description of My Financial Interest** *(Describe in what manner the public servant or "dependent" expects to derive a profit or financial benefit from, or otherwise has a pecuniary interest in, the above contract(s) or purchase(s); if reasonably determinable, state the approximate dollar value of such profit or benefit.):*

I am the principal shareholder of all the entities mentioned in question 5, above.  
\_\_\_\_\_  
\_\_\_\_\_  
\_\_\_\_\_  
\_\_\_\_\_

*(Attach extra pages if additional space is needed.)*

8. **Approval of Appointing Officer or Body** *(To be completed if the public servant was appointed by an elected public servant or the board of trustees of a state-supported college or university.):*

I (We) being the \_\_\_\_\_ of  
*(Title of Officer or Name of Governing Body)*

\_\_\_\_\_ and having the power to appoint  
*(Name of Governmental Entity)*

the above named public servant to the public position to which he or she holds, hereby approve the participation to the appointed disclosing public servant in the above described contract(s) or purchase(s) in which said public servant has a conflict of interest as defined in Indiana Code 35-44.1-1-4; however, this approval does not waive any objection to any conflict prohibited by statute, rule, or regulation and is not to be construed as a consent to any illegal act.

_____	_____
_____	_____
_____	_____
Elected Official	Office

9. **Effective Dates** *(Conflict of interest statements must be submitted to the governmental entity prior to final action on the contract or purchase.):*

<u>08/09/2024</u>	_____
Date Submitted <i>(month, day, year)</i>	Date of Action on Contract or Purchase <i>(month, day, year)</i>

10. **Affirmation of Public Servant:** This disclosure was submitted to the governmental entity and accepted by the governmental entity in a public meeting of the governmental entity prior to final action on the contract or purchase. I affirm, under penalty of perjury, the truth and completeness of the statements made above, and that I am the above named public servant.

Signed:  President  
(Signature of Public Servant)

Date: 08/09/2024  
(month, day, year)

Printed Name: Corey M. Caylor  
(Please print legibly.)

Email Address: corey@onechoice.tech

Within fifteen (15) days after final action on the contract or purchase, copies of this statement must be filed with the State Board of Accounts by uploading it here [https://gateway.ifionline.org/sboa\\_coi/](https://gateway.ifionline.org/sboa_coi/) which is the preferred method of filing, or by mailing it to the State Board of Accounts, Indiana Government Center South, 302 West Washington Street, Room E418, Indianapolis, Indiana, 46204-2765 and the Clerk of the Circuit Court of the county where the governmental entity took final action on the contract or purchase.